

## VDE KLIJEŠTA SA POLUOKRUGLIM ČELJUSTIMA DIN ISO 5745, IEC 60900

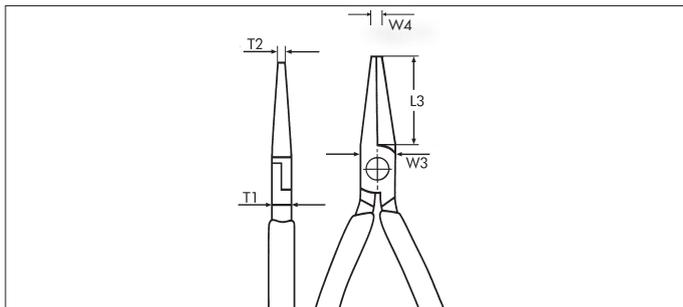

### Za hvatanje, držanje i sječenje mekše i tvrde žice i kablova

- U skladu sa propisanim mjerama sigurnosti, za rad pod naponom do 1.000 V (AC), ili do 1.500 V (DC)
- Visokokvalitetni alatni čelik osigurava dug radni vijek preciznih vrhova i reznih površina
- Elastični vrhovi za visoka opterećenja, posebno pod opterećenjima od savijanja
- Ergonomični 2-komponentni udobni rukohvati sa širokom VDE kragom za siguran rad

Rezne ivice: dodatno induktivno kaljene

Površina: brušena i kromirana sa svih strana

Stezne površine: nazubljene

Zglob: umetnut

L mm	L inch	Geometrija vrha	Oblik čeljusti	L3 mm	W3 mm	T1 mm	W4 mm	T2 mm	Art.-Nr.	Pak./ kom.
210	8 1/4			76	17,5	9,5	4	3	<b>0714 01 577</b>	1
210	8 1/4		 40° 	72	17,5	9,5	4	3	<b>0714 01 578</b>	
160	6 1/2			50	16,5	9	3	2,5	<b>0714 01 579</b>	
160	6 1/2		 40° 	46	16,5	9	3	2,5	<b>0714 01 596</b>	